

opera | *Stefano Sandonà e Sabrina Bettini*



Un guscio avvolgente, che racchiude la schiena grazie alle sue forme sinuose. La famiglia Opera apre un nuovo capitolo tra le sedute direzionali Leyform. Un nuovo modo di intendere la comodità, attraverso linee fluide che scolpiscono la materia, capaci di disegnare una forma solida e plastica allo stesso tempo.

An enveloping shell, that embraces the entire back thanks to its sinuous design. The Opera collection opens a new chapter in Leyform executive chairs. A new way of conceiving the comfort through fluid lines that sculpt the matter, capable of designing, at the same time, a solid, yet soft shape.

Une coque enveloppant qui contient le dos grâce à sa forme sinueuse. La collection Opera ouvre un nouveau chapitre dans le segment Direction de Leyform. Une nouvelle façon de concevoir le confort à travers des lignes fluides qui sculptent la matière, capables de dessiner une forme solide et souple au même temps.

Eine umhüllende Schale, die den Rücken dank ihrer geschwungenen Formen umschließt. Die Opera-Kollektion eröffnet ein neues Kapitel unter Leyform Chefesseln. Eine neue Art, den Komfort zu interpretieren, durch fließende Linien, die das Material meißeln und eine solide und gleichzeitig weiche Form zeichnen.





EN
1335

1 IM

CAM

Certificazioni prodotto
Certifications
Certifications
Zertifizierungen



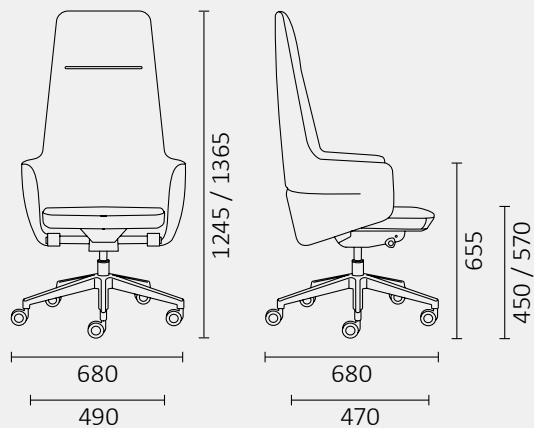
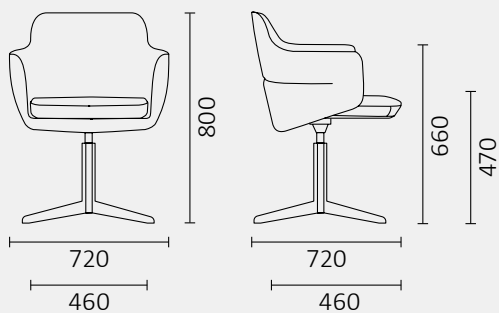

COD



COD	655	450/570	1245/1365	680	490	680	/	2,48	4,51	0,50	21,00	25,00
2900	655	450/570	1245/1365	680	490	680	/	2,48	4,51	0,50	21,00	25,00
2920	655	450/570	990/1110	680	490	680	/	2,11	3,83	0,38	20,00	24,00
2942	585	395/520	720/845	680	460	680	/	1,57	2,86	0,25	13,50	17,50
2940	660	470	800	720	460	720	/	1,57	2,86	0,35	13,50	17,50

Sedile

Il sedile è composto da legno multistrato, spessore di 15 mm, incollato ad alta frequenza con colla a bassa emissione di formaldeide (classe E1).

Struttura

Schienale con struttura metallica.

Imbottitura

L'imbottitura del sedile e dello schienale è in poliuretano schiumato a freddo ignifuga.

Rivestimento

Vedi dati tecnici su cartelline di riferimento.

Meccanismo

- EPRON PLUS SYNCHRON: Il meccanismo è un movimento oscillante sincronizzato sedile/schienale, in pressofusione di alluminio + acciaio verniciato nero, con arresto regolabile in 4 posizioni e sicurezza anti-ribaltamento per lo svincolo dello schienale. Intensità di oscillazione regolabile lateralmente,
- PIASTRA: in acciaio con leva gas nelle versioni con altezza regolabile.

Pistone

Dispositivo a gas per la regolazione in altezza del sedile.

Basamento

- Base 5 razze realizzato in lega di alluminio, pressofusa e lucidata.
- Base 4 razze in alluminio lucido Ø 720 mm con pistone auto allineante (torna) e piedini.

Ruote

Ruote gommate con freno Ø 65 mm (forate).

Braccioli

Inclusi nello schienale.

Modifiche

Leyform si riserva il diritto di apportare modifiche in qualsiasi momento al fine di migliorare la propria produzione.

Seat

The seat is made of 15 mm thick multilayer wood, high-frequency glued with low formaldehyde emission adhesive (class E1).

Structure

Backrest with metal frame.

Padding

The seat and backrest padding is made of cold-moulded fire-retardant polyurethane foam.

Upholstery

See technical data in the reference folders.

Mechanism

- EPRON PLUS SYNCHRON: The mechanism features a synchronized tilting movement seat/backrest, made of die-cast aluminium + black-painted steel, with 4 locking positions and an anti-shock safety system for backrest release. The tilt tension is laterally adjustable.
- PIASTRA: Steel plate with gas lift lever for height-adjustable versions.

Gas lift

Gas device for seat height adjustment.

Base

- 5-star base made of polished die-cast aluminium.
- 4-star base in polished aluminium Ø 720 mm with self-return gas lift and glides.

Castors

Rubber castors with brake Ø 65 mm (open type).

Armrests

Integrated into the backrest.

Modifications

Leyform reserves the right to make changes at any time in order to improve its production.

Assise

L'assise est composée de bois multiplis d'une épaisseur de 15 mm, collé à haute fréquence avec une colle à faible émission de formaldéhyde (classe E1).

Structure

Dossier avec structure métallique.

Rembourrage

Le rembourrage de l'assise et du dossier est en mousse de polyuréthane moulée à froid, ignifugée.

Revêtement

Voir les données techniques dans les fiches de référence.

Mécanisme

- EPRON PLUS SYNCHRON : mécanisme avec un mouvement oscillant synchronisé assise/dossier, en aluminium moulé sous pression + acier peint en noir, avec blocage réglable en 4 positions et sécurité anti-basculement pour le déverrouillage du dossier. L'intensité de l'oscillation est réglable latéralement.
- PIASTRA : En acier avec levier à gaz pour les versions à hauteur réglable.

Vérin à gaz

Dispositif à gaz pour le réglage en hauteur de l'assise.

Piètement

- Piètement à 5 branches en alliage d'aluminium poli, moulé sous pression.
- Piètement à 4 branches en aluminium poli Ø 720 mm avec vérin auto-alignant (retour) et patins.

Roulettes

Roulettes caoutchoutées avec frein Ø 65 mm (perforées).

Accoudoirs

Intégrés au dossier.

Modifications

Leyform se réserve le droit d'apporter à tout moment des modifications afin d'améliorer sa production.

Sitz

Der Sitz besteht aus Buchensperrholz, Stärke 15 mm, hochfrequenzverleimt mit einem Kleber mit geringer Formaldehyd-Emission (Klasse E1).

Struktur

Rückenlehne mit Metallstruktur.

Polsterung

Die Polsterung von Sitz und Rückenlehne besteht aus feuerhemmendem Polyurethan-Kaltformschaum.

Bezug

Siehe technische Daten auf den entsprechenden Musterkarten.

Mechanismus

EPRON PLUS SYNCHRON: Synchronisierte Sitz-/Rückenlehnen-Wippmechanik aus Aluminium-Druckguss + schwarz lackiertem Stahl, arretierbar in 4 Positionen mit Antischock-Sicherheitssperre zur Freigabe der Rückenlehne. Seitlich einstellbare Schwingintensität.

PLATTE: Aus Stahl mit Gashebel für höhenverstellbare Versionen.

Gasfeder

Gasdruckfeder zur Sitzhöhenverstellung.

Gestell

5-Stern-Fußkreuz aus polierter Aluminium-Druckgusslegierung.

4-Stern-Fußkreuz aus poliertem Aluminium Ø 720 mm mit selbstzentrierender Gasfeder (Rückholfunktion) und Gleitern.

Rollen

Gummierte Rollen mit Sicherheitsbremse Ø 65 mm (lochdesign).

Armlehnen

In der Rückenlehne integriert.

Änderungen

Leyform behält sich das Recht vor, jederzeit Änderungen vorzunehmen, um die eigene Produktion zu verbessern.

SCHIENALE

backrest / dossier / Rückenlehne



CORDINO

pipng / passepoil / Keder



BICOLORE

two-tone colour upholstery / revêtement bi-couleur / zweifarbige Bezugsfarben



BASAMENTI

bases / piétements / Fussgestelle



 **leyform**

Via Pertini, 1, 31014 Colle Umberto
Treviso - Italy
Tel +39 0438 430 050
Fax +39 0438 430 487

www.leyform.com
info@leyform.com

Ultima revisione
Last revision
Dernière révision
Letzte Überarbeitung

Rev.00 del 17/07/2024

